

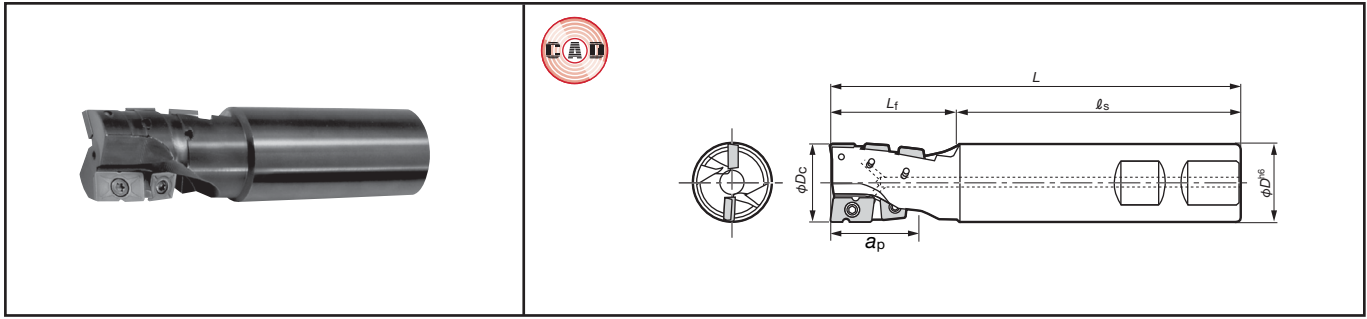

For roughing, large-depth shouldering, and slotting of steels and cast irons



Cat. No.	Stock	Effective No. of teeth () : insert	Dimensions (mm)					Air hole	Applicable inserts	Clamping screw	Wrench	
			ϕD_c	L	L_f	l_s	ϕD_s					a_p
ELP13025RA-A	●	2 (5)	25	130	40	90	25	28	With	APMT070308PN-MJ	CSPB-2.5	IP-8D
ELP13025RA	●								Without	ADMT130308PR-MJ	CSPD-3	IP-10D
ELP17032RA-A	●		32	140	50		32	35	With	APMT09T308PN-MJ	CSPD-3	IP-10D
ELP17032RA	●								Without	ADMT17T308PR-MJ	CSPB-4S	IP-15D
ELP21040RA-A	●		40	150	60		42	44	With	APMT120408PN-MJ	CSPB-4	IP-15D
ELP21040RA	●								Without	ADMT210408PR-MJ	CSTB-5	T-20D

Inserts

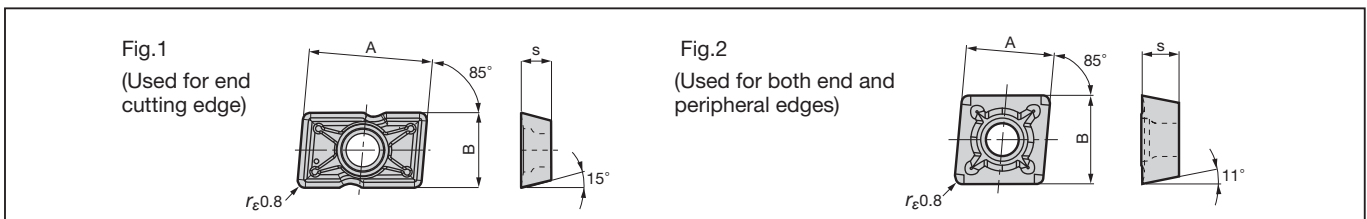

Cat. No.	Accuracy	Honing	Insert grades				Dimensions (mm)			Figure
			AH120	AH140	T3130	T3030	A	B	s	
APMT070308PN-MJ	M	With	●	●	●	●	7.94	7.94	3.18	Fig.2
APMT09T308PN-MJ			●	●	●	●	9.525	9.525	3.97	
APMT120408PN-MJ			●	●	●	●	12.7	12.7	4.76	
ADMT130308PR-MJ			●	●	●	●	13.1	7.94	3.18	Fig.1
ADMT17T308PR-MJ			●	●	●	●	16.6	9.525	3.97	
ADMT210408PR-MJ			●	●	●	●	20.6	12.7	4.76	

Standard cutting conditions

Work materials	Insert grades	Cutter diameter (mm)					
		$\phi 25$		$\phi 32$		$\phi 40$	
		$v_c(\text{m/min})$	$f_z(\text{mm/t})$	$v_c(\text{m/min})$	$f_z(\text{mm/t})$	$v_c(\text{m/min})$	$f_z(\text{mm/t})$
Mild steels, Low carbon steels SS400, S25C etc.	T3130-T3030 (AH120)	60~150	0.08~0.2	60~150	0.1~0.3	60~150	0.1~0.3
High carbon steels, Alloy steels S50C, SCM440 etc.		60~120		60~120		60~120	
Die steels SKD11 etc.		60~100		60~100		60~100	
Stainless steels SUS304 etc.	AH140	70~120	0.08~0.2	70~120	0.1~0.3	70~120	0.1~0.3
Cast irons FC250, FCD500 etc.	AH120	60~150	0.08~0.2	60~150	0.1~0.3	60~150	0.1~0.3

- v_c : Cutting speed
- f_z : Feed per tooth (Feed per revolution is $f_z \times 2$ as effective number of teeth is equal to two)

Notes : • To get the best of the tool's performance, use of a high-accuracy, side-lock type toolholder or milling chuck which has a high gripping force is recommended.
• Excessive tool overhang from the toolholder should be avoided to prevent chatter.

● : Stocked in Japan.