

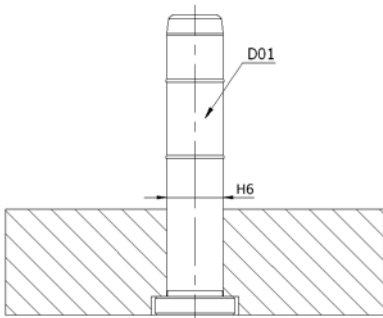

Malzeme - Material : Asil Çelik 1.1213 (Cf 53)
Sertlik - Hardness : 62± 2 HRC
Isil İşlem - Heat Treatment : Islah + İndüksiyon
(Allowence + Induction)

■ Bordo renkteki sipariş kodları yeni ilave olan ölçülerimizdir.

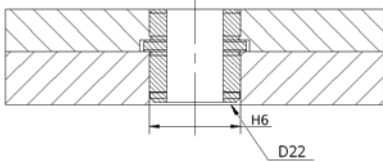
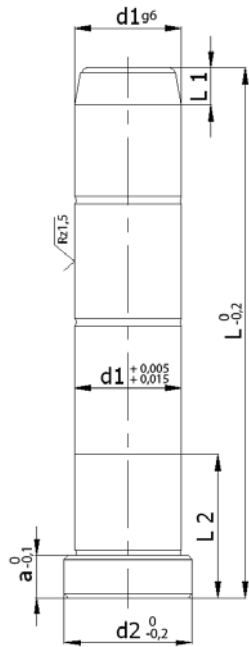

Sipariş Kodu	Ød1	L	L1	L2	d2	a
D01_1040	10	40	4	17	12	3
D01_1060		60				
D01_1080		80		22		
D01_10100		100		27		
D01_10120		120				
D01_1240	12	40	7	17	16	6
D01_1260		60		22		
D01_1280		80		27		
D01_12100		100				
D01_12120		120		36		
D01_12140		140				
D01_12160		160				
D01_1460	14	60	7	17	18	8
D01_1480		80		22		
D01_14100		100		27		
D01_14120		120		36		
D01_14140		140				
D01_14160		160				
D01_14180		180		46		
D01_1640	16	40	7	22	20	8
D01_1660		60		27		
D01_1680		80				
D01_16100		100		36		
D01_16120		120				
D01_16140		140				
D01_16160		160		46		
D01_16180		180				
D01_16200		200		56		
D01_1860	18	60	7	27	22	8
D01_1880		80				
D01_18100		100		36		
D01_18120		120				
D01_18140		140				
D01_18160		160		46		
D01_18180		180				
D01_18200		200		56		
D01_18240		240				
D01_2060	20	60	7	27	24	8
D01_2080		80				
D01_20100		100		36		
D01_20120		120				
D01_20140		140				
D01_20160		160		46		
D01_20180		180				
D01_20200		200		56		
D01_20240		240		76		

Sipariş Kodu	Ød1	L	L1	L2	d2	a
D01_2280	22	80	7	36	26	15
D01_22100		100				
D01_22120		120				
D01_22140		140				
D01_22160		160		46		
D01_22180		180		56		
D01_22200		200				
D01_22220		220				
D01_22240		240		66		
D01_22300		300				
D01_2480	24	80	7	36	28	15
D01_24100		100				
D01_24120		120				
D01_24140		140				
D01_24160		160		46		
D01_24180		180		56		
D01_24200		200				
D01_24220		220				
D01_24240		240		66		
D01_24300		300				
D01_30100	30	100	7	36	36	15
D01_30120		120				
D01_30140		140				
D01_30160		160		46		
D01_30180		180		56		
D01_30200		200		66		
D01_30220		220				
D01_30240		240				
D01_30300		300		76		
D01_30360		360				
D01_40160	40	160	10	46	48	15
D01_40180		180		56		
D01_40200		200		66		
D01_40220		220				
D01_40240		240				
D01_40280		280				
D01_40300		300		76		
D01_40320		320				
D01_40360		360				
D01_50160	50	160	10	56	58	15
D01_50200		200				
D01_50240		240				
D01_50300		300		66		
D01_50360		360		76		