

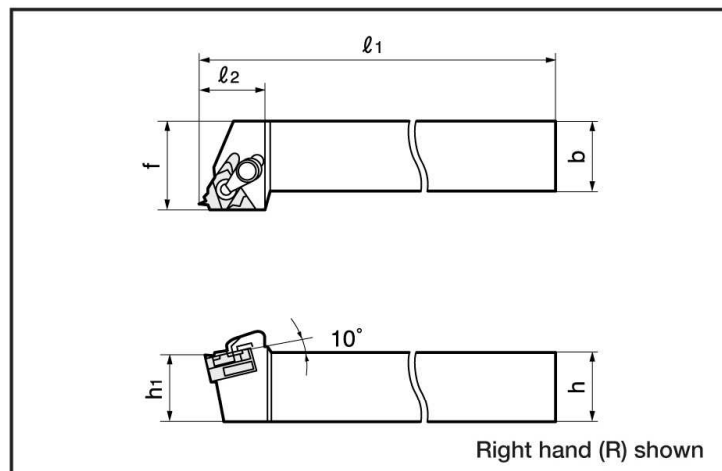

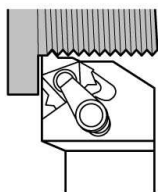

ST-type Toolholder (Clamp-on type)

External threading
CE R/L T

Cat. No.	Stock		Insert	Dimensions (mm)						Clamping set 	Shim set		Clamping screw —	Wrench 	
	R	L		h	b	l1	l2	h1	f		f1	R 			L 
CER/L1212H16T			16ER/L□□□□	12	12	100	22	12	16	—	CSP16	GXE16-1	GXN16-1	—	T-15F
CER/L1616H16T				16	16	100	22	16	20	—					
CER/L2020K16T				20	20	125	22	20	25	—					
CER/L2525M16T				25	25	150	25	25	32	—					
CER/L3232P16T	●			32	32	170	32	32	40	—					
CER/L2525M22T			22ER/L□□□□	25	25	150	28	25	32	—	CSP22	NXE22-1	NXN22-1	—	T-20F
CER/L3232P22T	●			32	32	170	32	32	40	—					
CER/L4040R22T				40	40	200	36	40	50	—					
CER/L2525M27T		○	27ER/L□□□□	25	25	150	34	25	32	—	CSP27	NXE27-1	NXN27-1	—	P-4
CER/L3232P27T		○		32	32	170	34	32	40	—					
CER/L4040R27T				40	40	200	40	40	50	—					

Notes:

- Clamping sets for CER/L type consist of a clamp and a clamping screw.
- Shim sets for CER/L type consist of a shim and a shim screw.
- Standard shims for CER/L type can be used for both the left hand and right-hand toolholder. Use either of the sides depending on the hand.