

Internal profiling

PTUN R/L

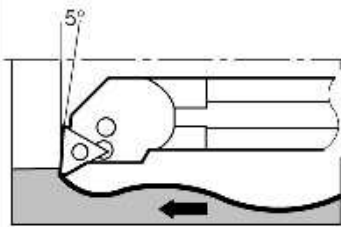

Cutting edge style **U**

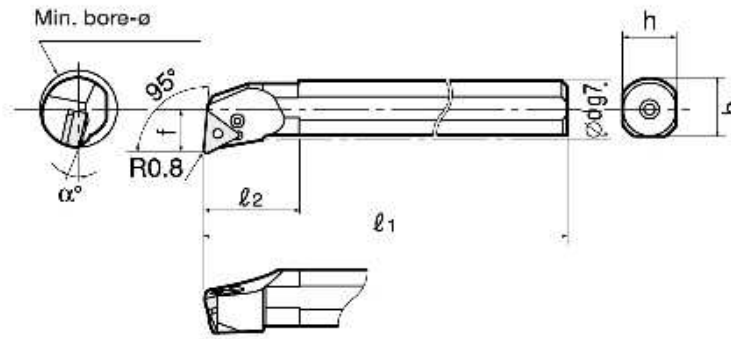

Right hand (R) shown

● Basic-choice chipbreaker

Appl.	Precision finishing	Finishing	Medium cutting	Medium cutting
Type	TF	TS	TM	CB
Shape	(16)	(16)	(11, 16)	(11, 16)

Appl.	Medium cutting	Medium cutting	Medium cutting	Precision finishing
Type	SM	CM	P	PCBN/PCD
Shape	(16)	(16)	(16)	(16)

For details see pp. 70 - 76

Shank material	Cat. No.	Stock		Insert	Min. bore dia. øD	Std. Nose R	Dimensions (mm)						Shim	Lever	Clamping screw	Spring	Wrench	
		R	L				ød	f	l ₁	l ₂	h	b						α°
Steel	S16M-PTUNR/L11	●	●	TN□□1103□□	20	0.4	16	11	150	30	15	15.5	14°	—	LCL22N	LCS22A	—	P-2F
	S20Q-PTUNR/L11	●	●		25		20	13	180	35	18	19	12°					
	S25R-PTUNR/L16	●	●	TN□□1604□□	32	0.8	25	17	200	40	23	24	12°	ELST317B R/L	LCL33	LCS3	LSP3	P-2.5