

DHB - Files

Description & Use:

STRAUSS & CO.'s **DHB Files** can be used by hand or in any reciprocating filing machine such as the PJ120K. These files are specially designed for the aluminum extruders industry as well as for the plastic mold industry. Main application of these tapered files is internal filing in slots and grooves, where access with parallel files is impossible. The set of DHB files includes 10 files in 3 different grit sizes and offers a comprehensive solution to all filing and finishing jobs inside slots.

Size:

Total length 72/56mm. Diamond coated length 15mm.

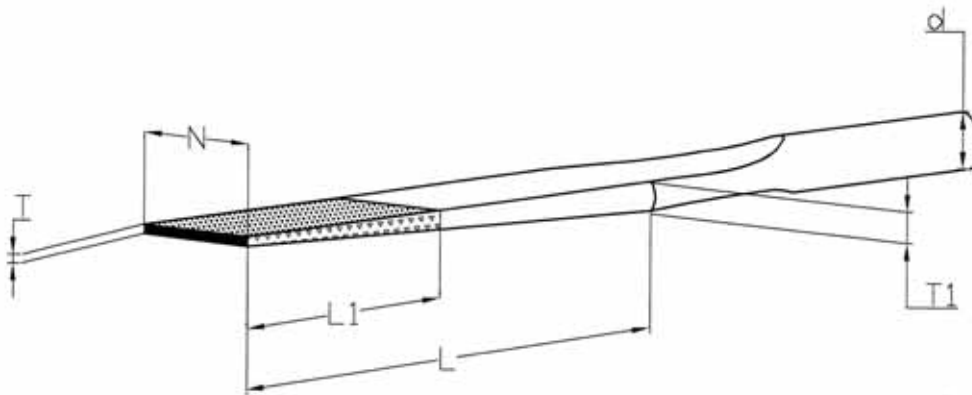
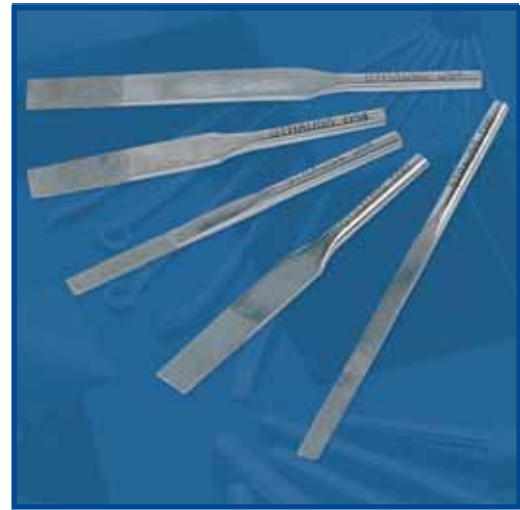

Cat. No.	Grit Size	T	N	L	L1	T1	d	Total Length
DHB31530	D54	0.55	3.15	30	15	1.8	3.0	57
DHB31530	D91	0.65	3.25	30	15	1.8	3.0	57
DHB31545	D30	0.45	3.05	45	15	1.5	3.0	73
DHB31545	D54	0.55	3.15	45	15	1.5	3.0	73
DHB31545	D91	0.65	3.25	45	15	1.5	3.0	73
DHB61530	D30	0.45	6.05	30	15	1.0	3.0	57
DHB61530	D54	0.55	6.15	30	15	1.0	3.0	57
DHB61545	D30	0.45	6.05	45	15	1.0	3.0	73
DHB61545	D54	0.55	6.15	45	15	1.0	3.0	73
DHB61545	D91	0.65	6.25	45	15	1.0	3.0	73

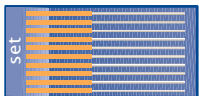

Cat. No. DHB36SET

The DHB set includes one of each of the above files.

Remarks:

Tolerance: Length ± 1.0 mm. Profile ± 0.5 mm.

