



Round Piercing Punches

DIN 9861 Part 1 Type DA

Standard finish

- with continuous shaft
- with 60° conical head

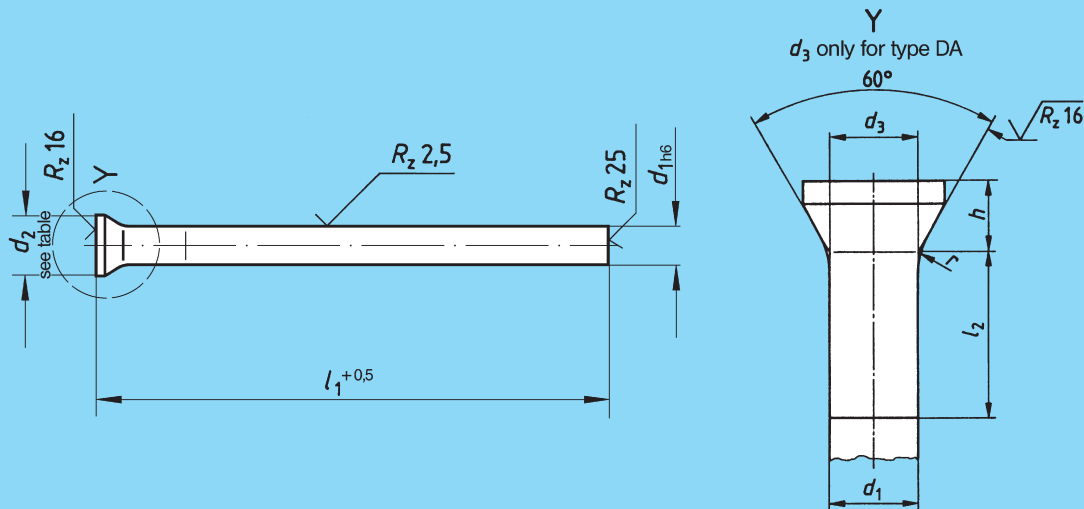

Range of application

For press tools used for piercing/cutting sheet, steel, non-ferrous metals, plastics, paper (for basic printed circuit board material with smooth surface).

Size/head size

See table pages 7-9 and 14-15, all dimensions are in mm

Fit/tolerances

Nominal diameter d_1 (shaft)

	0,50 - 3,00 Ø	≥ 3,00 - 6,00 Ø	≥ 6,00 - 10,00 Ø	≥ 10,00 - 18,00 Ø	≥ 18,00 - 20,00 Ø
h6	- 0,006	- 0,008	- 0,009	- 0,011	- 0,013

Length: total $l_1^{+0,5}$

All other tolerances: see illustration and table respectively for non-specified tolerances in accordance with ISO 2768-m

Material

- WS: Alloyed cold working steel
- HWS: High alloy cold working steel (approx. 12% Chrome)
- HSS: High speed steel

Material properties

- WS: For working medium strength materials.
- HWS: For working higher strength materials. High wear resistance - long life.
- HSS: For working high strength or difficult to work materials. Very abrasion proof high tensile strength and high heat resistance.

Hardness

		WS	HWS	HSS
Shaft:	HRC	60 - 64	60 - 64	62 - 66
Head:	HRC	40 - 50	45 - 55	45 - 55

Finish

Hardened, annealed, shaft precision ground, 60° countersunk head hot formed, with permissible swelling d_3 immediately below the head.

Please note

For extremely high demands we would recommend piercing punches made from powdered high speed steel (pages 10/13) or with bottle or trombone neck (pages 20/21 and 22/23).

HSS piercing punches can be treated with a special surface coating on request (pages 42/43).

Piercing punches made from tungsten carbide are also available (pages 42/43).

Other materials on request.

Standard dimensions

Piercing punches type DA-WS

Shaft-Ø d ₁ h6	Total length l ₁ +0,5			Shaft-Ø d ₁ h6	Total length l ₁ +0,5			Shaft-Ø d ₁ h6	Total length l ₁ +0,5		
	71	80	100		71	80	100		71	80	100
0,5				3,6				10,0			
0,55				3,7				10,5			
0,6				3,8				11,0			
0,65				3,9				11,5			
0,7				4,0				12,0			
0,75				4,1				12,5			
0,8				4,2				13,0			
0,85				4,3				13,5			
0,9				4,4				14,0			
0,95				4,5				14,5			
1,0				4,6				15,0			
1,1				4,7				15,5			
1,2				4,8				16,0			
1,3				4,9							
1,4				5,0							
1,5				5,1							
1,6				5,2							
1,7				5,3							
1,8				5,4							
1,9				5,5							
2,0				5,6							
2,1				5,7							
2,2				5,8							
2,3				5,9							
2,4				6,0							
2,5				6,1							
2,6				6,2							
2,7				6,3							
2,8				6,4							
2,9				6,5							
3,0				7,0							
3,1				7,5							
3,2				8,0							
3,3				8,5							
3,4				9,0							
3,5				9,5							

The filled-in spaces indicate standard dimensions. Special dimensions on request.
For head sizes see table pages 14 and 15.

Standard dimensions

Piercing punches type DA-HWS

Shaft-Ø d ₁ h6	Total length l ₁ + ^{0,5}			Shaft-Ø d ₁ h6	Total length l ₁ + ^{0,5}			Shaft-Ø d ₁ h6	Total length l ₁ + ^{0,5}		
	71	80	100		71	80	100		71	80	100
0,5				2,9				7,6			
0,55				2,95				7,7			
0,6				3,0				7,8			
0,65				3,1				7,9			
0,7				3,2				8,0			
0,75				3,3				8,1			
0,8				3,4				8,2			
0,85				3,5				8,3			
0,9				3,6				8,4			
0,95				3,7				8,5			
1,0				3,8				8,6			
1,05				3,9				8,7			
1,1				4,0				8,8			
1,15				4,1				8,9			
1,2				4,2				9,0			
1,25				4,3				9,1			
1,3				4,4				9,2			
1,35				4,5				9,3			
1,4				4,6				9,4			
1,45				4,7				9,5			
1,5				4,8				9,6			
1,55				4,9				9,7			
1,6				5,0				9,8			
1,65				5,1				9,9			
1,7				5,2				10,0			
1,75				5,3				10,5			
1,8				5,4				11,0			
1,85				5,5				11,5			
1,9				5,6				12,0			
1,95				5,7				12,5			
2,0				5,8				13,0			
2,05				5,9				13,5			
2,1				6,0				14,0			
2,15				6,1				14,5			
2,2				6,2				15,0			
2,25				6,3				15,5			
2,3				6,4				16,0			
2,35				6,5				16,5			
2,4				6,6				17,0			
2,45				6,7				17,5			
2,5				6,8				18,0			
2,55				6,9				18,5			
2,6				7,0				19,0			
2,65				7,1				19,5			
2,7				7,2				20,0			
2,75				7,3							
2,8				7,4							
2,85				7,5							

The filled-in spaces indicate standard dimensions. Special dimensions on request.
For head sizes see table pages 14 and 15.

Standard dimensions

Piercing punches type DA-HSS

Shaft-Ø d ₁ h6	Total length l ₁ + ^{0,5}			Shaft-Ø d ₁ h6	Total length l ₁ + ^{0,5}		
	71	80	100		71	80	100
0,5				3,6			
0,55				3,7			
0,6				3,8			
0,65				3,9			
0,7				4,0			
0,75				4,1			
0,8				4,2			
0,85				4,3			
0,9				4,4			
0,95				4,5			
1,0				4,6			
1,1				4,7			
1,2				4,8			
1,3				4,9			
1,4				5,0			
1,5				5,1			
1,6				5,2			
1,7				5,3			
1,8				5,4			
1,9				5,5			
2,0				5,6			
2,1				5,7			
2,2				5,8			
2,3				5,9			
2,4				6,0			
2,5				6,1			
2,6				6,2			
2,7				6,3			
2,8				6,4			
2,9				6,5			
3,0				7,0			
3,1				7,5			
3,2				8,0			
3,3				8,5			
3,4				9,0			
3,5				9,5			
				10,0			

The filled-in spaces indicate standard dimensions. Special dimensions on request.
For head sizes see table pages 14 and 15.