

# Dial Indicator

## SERIES 2 — Standard Type, 0.01mm Resolution

Series 2 dial indicators are Mitutoyo's most popular, and have the widest application.

### FEATURES

- Standard 0.01mm graduation dial gauges having an outer frame with an outside diameter of 57mm. All types come with limit pins and an outer frame clamp as standard.
- The outer clamp and lifting lever (optional) can be attached to either the right or left side. These parts can be easily installed and removed without tools.
- Secured adhesion between the outer frame and crystal as well as the use of an O-ring ensure countermeasures against water and oil permeation via the front face.
- The stem spindle is made of high-strength quenched-hardened stainless steel which resists strenuous use.
- A carbide contact point is used.
- The grand gear uses stainless steel that is resistant to wear and deformation.
- Application of a hard coating on the surface of the crystal makes the gauge highly scratch- and chemical-resistant.



(Refer to the page 9 for details.)



2046S



2046S-60



2046S  
2046SH  
2046S-09  
2046S-15  
2046S-80  
2046SLB



2046SY



2046S-60  
2046S-69



2047S



Shockproof type



Waterproof type



Long stem type



Jeweled bearing type



w/ coaxial revolution counter



Reverse reading type

## SPECIFICATIONS

Metric

ISO/JIS type

Graduation	Order No.		Range (range/rev)	Accuracy	Dial reading	Measuring force						
	w/ lug	Flat-back										
0.01mm	2044S	2044SB	5mm (1mm)	±12μm	0-100	1.4N or less	—	—	—	—	—	—
0.01mm	2044S-09	2044SB-09	5mm (1mm)	±13μm	0-100	1.4N or less	✓	—	—	—	—	—
0.01mm	2044S-60	2044SB-60	5mm (1mm)	±12μm	0-100	2.5N or less	—	✓	—	—	—	—
0.01mm	2045S	2045SB	5mm (1mm)	±12μm	0-50-0	1.4N or less	—	—	—	—	—	—
0.01mm	2046S	2046SB	10mm (1mm)	±13μm	0-100	1.4N or less	—	—	—	—	—	—
0.01mm	2046SY	2046SYB	10mm (1mm)	±13μm	0-100	1.4N or less	—	—	—	—	—	—
0.01mm	2046SH	2046SHB	10mm (1mm)	±8μm	0-100	1.4N or less	—	—	—	—	—	—
0.01mm	—	2046SLB	10mm (1mm)	±13μm	0-100	1.4N or less	—	—	✓	—	—	—
0.01mm	2046S-09	2046SB-09	10mm (1mm)	±15μm	0-100	1.4N or less	✓	—	—	—	—	—
0.01mm	2046S-60	2046SB-60	10mm (1mm)	±13μm	0-100	2.5N or less	—	✓	—	—	—	—
0.01mm	2046S-69	2046SB-69	10mm (1mm)	±15μm	0-100	2.5N or less	✓	✓	—	—	—	—
0.01mm	2046S-15	2046SB-15	10mm (1mm)	±13μm	0-100	0.8N or less*	—	—	—	✓	—	—
0.01mm	2310S-10	2310SB-10	10mm (1mm)	±15μm	0-100	1.4N or less	—	—	—	✓	✓	—
0.01mm	2902S	2902SB	10mm (1mm)	±13μm	100-0	1.4N or less	—	—	—	—	—	✓
0.01mm	2047S	2047SB	10mm (1mm)	±13μm	0-50-0	1.4N or less	—	—	—	—	—	—

\*Use in a vertical position only (contact point downward).

## DIMENSION

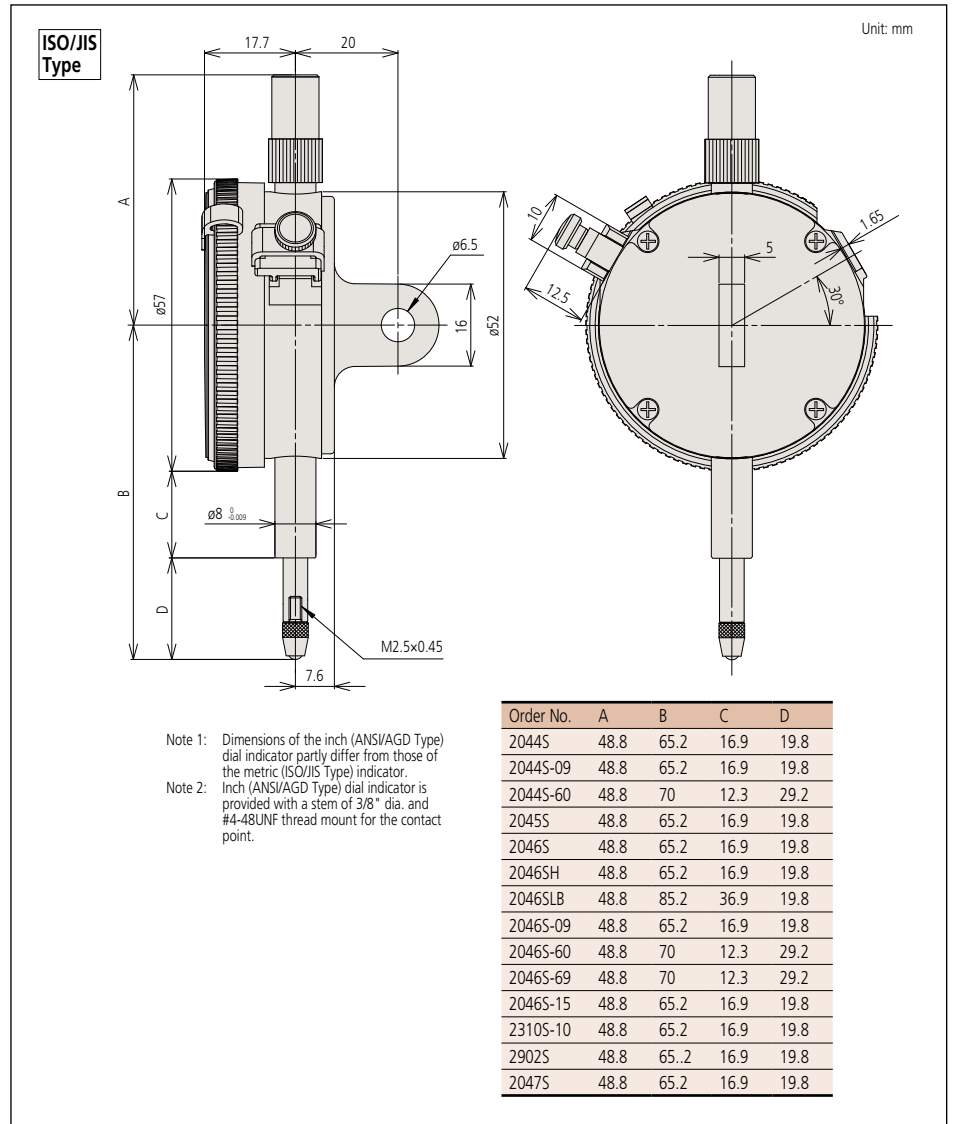

2902S



2310S-10



2044S  
2044S-60  
2044S-09



2045S

### Optional Accessory

- : Backs (See page 266.)
- : Contact points (See page 264.)