

## DHM - Files

### Description & Use:

*STRAUSS & CO.'s DHM Files* are specially designed for the aluminum extruders industry as well as the plastic mold industry. Main applications of these tapered files are filing inside slots and grooves, where access with parallel files is impossible. The set of DHM files includes 10 files in 3 different grit sizes and offers a comprehensive solution to all filing and finishing jobs inside slots. The DHM files have a round shank and can be used either by hand or in any reciprocating filing machine.

### Size:

Total length 130mm. Diamond coated length 30mm. Shank  $\varnothing$  3.0mm.

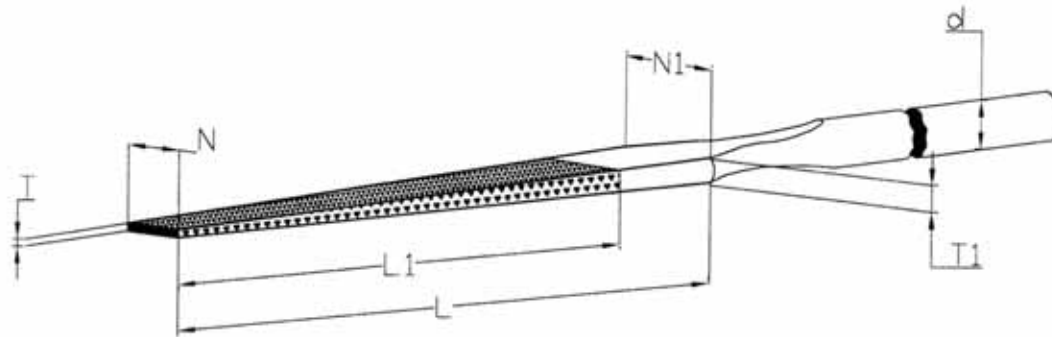

Cat. No.	Grit Size	T	N	N1	L	L1	T1	d	Total Length
DHM2	D30	0.35	2.05	2.0	44	30	2.70	3.0	130
DHM2	D54	0.45	2.15	2.0	44	30	2.70	3.0	130
DHM2	D91	0.55	2.25	2.0	44	30	2.70	3.0	130
DHM4	D30	0.35	4.05	4.0	38	30	1.30	3.0	130
DHM4	D54	0.45	4.15	4.0	38	30	1.30	3.0	130
DHM4	D91	0.55	4.25	4.0	38	30	1.30	3.0	130
DHM6	D30	0.35	5.55	5.5	38	30	1.35	3.0	130
DHM6	D54	0.45	5.65	5.5	38	30	1.35	3.0	130
DHM6	D91	0.55	5.75	5.5	38	30	1.35	3.0	130

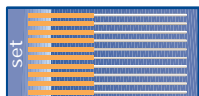

Cat. No. DHM246SET

The DHM set includes one of each of the above files and one MI8610D54 (see page no.7).

### Remarks:

Tolerance: Length  $\pm$ 1.0mm. Profile  $\pm$ 0.5mm.

