

# MS - Multi File System

## Description & Use:

STRAUSS & CO.'s unique **Multi File System** kit is widely used in the plastic molds and aluminium extruders industries. The unique design of the holding system allows "STRAUSS & CO." to manufacture these very **wide**, but still very **thin** flat files. The special design enables full contact between the whole surface of the file and the work piece. All the MS files are available individually (replacements) or as part of a kit.



Cat. No.	Size
MS15	15X15X68
MS25	25X25X68
MS15X1°	15X1°X25X78
MSHANDLE	Special Multi Grip Holder
MS-HOLDER3	Holder For Filing Machine 3 mm Shank

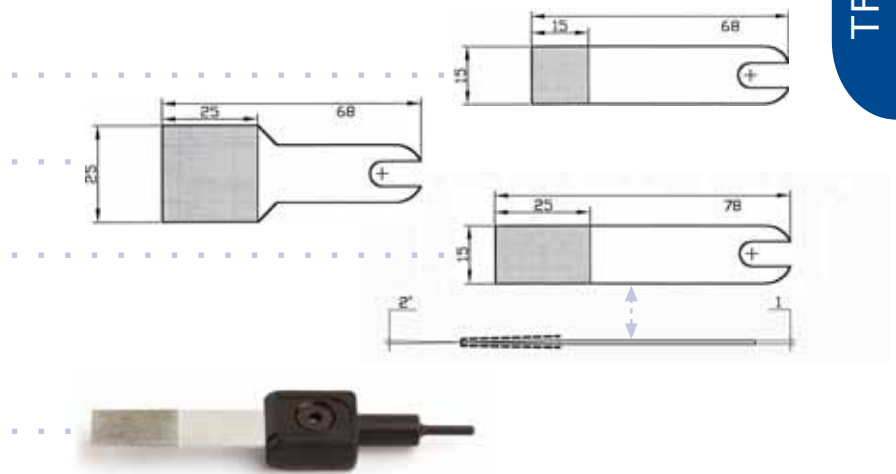

## Grit size:

The files are available in the following 4 grit sizes: D30 (#600), D54 (#325/400), D91 (#170/200), D126 (#120/140). Also available with coating on one side only.

## Thickness of files:

MS15-D30 = 0.4mm.	MS25-D30 = 0.4mm.
MS15-D54 = 0.5mm.	MS25-D54 = 0.5mm.
MS15-D91 = 1.0mm.	MS25-D91 = 1.0mm.
MS15-D126 = 1.2mm.	MS25-D126 = 1.2mm.

Files are available in the following kits, (each kit includes a wrench and is packed in a specially designed case):

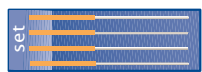

**Cat. No. MSSET1:** One of each of the following: MSHANDLE, MS15-D30, MS15-D54, MS25-D30 AND MS25-D54.



**Cat. No. MSSET2:** One of each of the following: MSHANDLE, MS15-D91, MS15-D126, MS25-D91 AND MS25-D126.

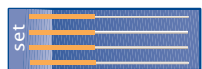

**Cat. No. MSSET3:** One of each of the following: MSHANDLE, MS25-D30, MS25-D54, MS25-D91 AND MS25-D126.

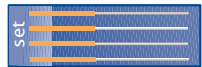

**Cat. No. MSSET-SVC:** One of each of the following: MSHANDLE, MS15X1°-D54, MS15X1°-D91, AND MS15X1°-D126.

Tolerance: Thickness  $\pm 0.15$ mm. Profile  $\pm 0.3$ mm.

