



Round Piercing Punches

DIN 9861 Part 1 Type D

Precision finish

- with continuous shaft
- with 60° conical head
- plunge cut ground

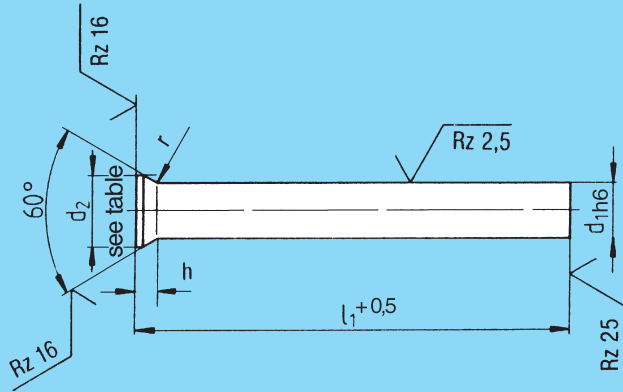

Range of application

For press tools used for piercing/cutting sheet, steel, non-ferrous metals, plastics, paper, for basic printed circuit board material.

Size/head size

See table pages 11-13 and 14-15, all dimensions are in mm

Fit/tolerances

Nominal diameter d_1 (shaft)

	0,50 - 3,00 Ø	≥ 3,00 - 6,00 Ø	≥ 6,00 - 10,00 Ø	≥ 10,00 - 18,00 Ø	≥ 18,00 - 20,00 Ø
h6	- 0,006	- 0,008	- 0,009	- 0,011	- 0,013

Length: total $l_1^{+0,5}$

All other tolerances: see illustration and table respectively for non-specified tolerances in accordance with ISO 2768-m

Material

HWS: High alloy cold working steel (approx. 12 % Chrome)

HSS: High speed steel

ASP 2023: Powder metallurgy manufactured high speed steel

Material properties

HWS: For working higher strength materials. High wear resistance - long life.

HSS: For working high strength or difficult to work materials. Very abrasion proof high tensile strength and high heat resistance.

ASP 2023: A noticeable increase in the life expectancy, e.g. when piercing stainless materials

Hardness

		HWS	HSS	ASP 2023
Shaft:	HRC	60 - 64	62 - 66	62 - 66
Head:	HRC	45 - 55	45 - 55	45 - 55

Finish

Hardened, annealed, 60° countersunk head hot formed, subsequently the shaft is plunge cut ground over the whole length including the 60° countersunk, head surface ground.

Please note

For extremely high demands we would recommend piercing punches with bottle or trombone neck (pages 20/21 and 22/23)

HSS piercing punches can be treated with a special surface coating on request (pages 42/43).

Piercing punches made from tungsten carbide are also available (pages 42/43)

Other materials on request.

Standard dimensions

Piercing punches type D-HWS

Shaft-Ø d ₁ h ₆	Total length l ₁ +0,5			Shaft-Ø d ₁ h ₆	Total length l ₁ +0,5			Shaft-Ø d ₁ h ₆	Total length l ₁ +0,5		
	71	80	100		71	80	100		71	80	100
0,5				2,9				7,6			
0,55				2,95				7,7			
0,6				3,0				7,8			
0,65				3,1				7,9			
0,7				3,2				8,0			
0,75				3,3				8,1			
0,8				3,4				8,2			
0,85				3,5				8,3			
0,9				3,6				8,4			
0,95				3,7				8,5			
1,0				3,8				8,6			
1,05				3,9				8,7			
1,1				4,0				8,8			
1,15				4,1				8,9			
1,2				4,2				9,0			
1,25				4,3				9,1			
1,3				4,4				9,2			
1,35				4,5				9,3			
1,4				4,6				9,4			
1,45				4,7				9,5			
1,5				4,8				9,6			
1,55				4,9				9,7			
1,6				5,0				9,8			
1,65				5,1				9,9			
1,7				5,2				10,0			
1,75				5,3				10,5			
1,8				5,4				11,0			
1,85				5,5				11,5			
1,9				5,6				12,0			
1,95				5,7				12,5			
2,0				5,8				13,0			
2,05				5,9				13,5			
2,1				6,0				14,0			
2,15				6,1				14,5			
2,2				6,2				15,0			
2,25				6,3				15,5			
2,3				6,4				16,0			
2,35				6,5				16,5			
2,4				6,6				17,0			
2,45				6,7				17,5			
2,5				6,8				18,0			
2,55				6,9				18,5			
2,6				7,0				19,0			
2,65				7,1				19,5			
2,7				7,2				20,0			
2,75				7,3							
2,8				7,4							
2,85				7,5							

The filled-in spaces indicate standard dimensions. Special dimensions on request.
For head sizes see table on pages 14 and 15.

Standard dimensions

Piercing punches type D-HSS

Shaft-Ø d ₁ h ₆	Total length l ₁ + ^{0,5}				Shaft-Ø d ₁ h ₆	Total length l ₁ + ^{0,5}				Shaft-Ø d ₁ h ₆	Total length l ₁ + ^{0,5}			
	71	80	100	130		71	80	100	130		71	80	100	130
0,5					2,9					7,6				
0,55					2,95					7,7				
0,6					3,0					7,8				
0,65					3,1					7,9				
0,7					3,2					8,0				
0,75					3,3					8,1				
0,8					3,4					8,2				
0,85					3,5					8,3				
0,9					3,6					8,4				
0,95					3,7					8,5				
1,0					3,8					8,6				
1,05					3,9					8,7				
1,1					4,0					8,8				
1,15					4,1					8,9				
1,2					4,2					9,0				
1,25					4,3					9,1				
1,3					4,4					9,2				
1,35					4,5					9,3				
1,4					4,6					9,4				
1,45					4,7					9,5				
1,5					4,8					9,6				
1,55					4,9					9,7				
1,6					5,0					9,8				
1,65					5,1					9,9				
1,7					5,2					10,0				
1,75					5,3					10,5				
1,8					5,4					11,0				
1,85					5,5					11,5				
1,9					5,6					12,0				
1,95					5,7					12,5				
2,0					5,8					13,0				
2,05					5,9					13,5				
2,1					6,0					14,0				
2,15					6,1					14,5				
2,2					6,2					15,0				
2,25					6,3					15,5				
2,3					6,4					16,0				
2,35					6,5					16,5				
2,4					6,6					17,0				
2,45					6,7					17,5				
2,5					6,8					18,0				
2,55					6,9					18,5				
2,6					7,0					19,0				
2,65					7,1					19,5				
2,7					7,2					20,0				
2,75					7,3									
2,8					7,4									
2,85					7,5									

The filled-in spaces indicate standard dimensions. Special dimensions on request.
For head sizes see table on pages 14 and 15.

Standard dimensions

Piercing punches type D-ASP 2023

Shaft-Ø d ₁ h6	Total length l ₁ +0,5			Shaft-Ø d ₁ h6	Total length l ₁ +0,5			Shaft-Ø d ₁ h6	Total length l ₁ +0,5		
	71	80	100		71	80	100		71	80	100
0,8				4,4				14,0			
0,9				4,5				14,5			
1,0				4,6				15,0			
1,1				4,7				15,5			
1,2				4,8				16,0			
1,3				4,9							
1,4				5,0							
1,5				5,1							
1,6				5,2							
1,7				5,3							
1,8				5,4							
1,9				5,5							
2,0				5,6							
2,1				5,7							
2,2				5,8							
2,3				5,9							
2,4				6,0							
2,5				6,1							
2,6				6,2							
2,7				6,3							
2,8				6,4							
2,9				6,5							
3,0				7,0							
3,1				7,5							
3,2				8,0							
3,3				8,5							
3,4				9,0							
3,5				9,5							
3,6				10,0							
3,7				10,5							
3,8				11,0							
3,9				11,5							
4,0				12,0							
4,1				12,5							
4,2				13,0							
4,3				13,5							

The filled-in spaces indicate standard dimensions. Special dimensions on request.
For head sizes see table on pages 14 and 15.