

Turning•Facing

MWLN R/L

Cutting edge style **L**

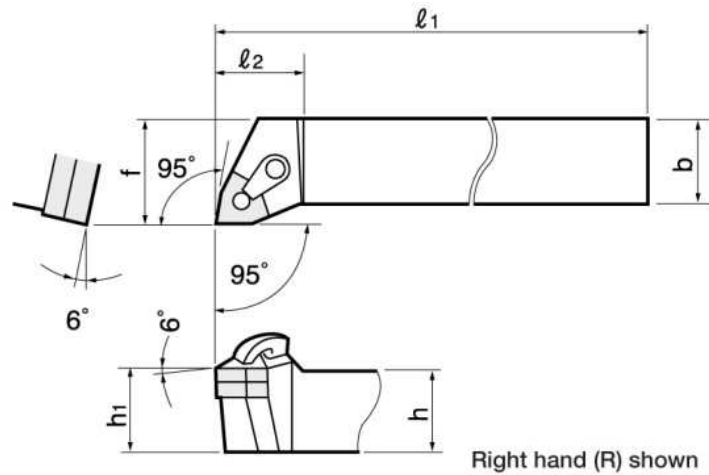

● Basic-choice chipbreaker

Appl.	Precision finishing	Finishing	Medium cutting	Roughing
Type	TF	TS	TM	TH
Shape	(08)	(08)	(08)	(08, 10)
Appl.	Heavy cutting	Medium cutting	Medium cutting	
Type	57	SM	CM	Ceramics
Shape	(08, 10, 13)	(08)	(08)	(08)

For details see pp. 78 - 82

Cat. No.	Stock		Insert	Std. Corner R	Dimensions (mm)						Shim	Lock pin	Shim screw	Clamp	Clamping screw	Breaker piece	Lock pin wrench	Wrench	
	R	L			h	b	l ₁	l ₂	h ₁	f	f ₁								
MWLN R/L2020K08	●	●	WNM□□0804□□	0.8	20	20	125	25	20	25	—	MSW-432	MLP46	—	MCPM-6	MCS 520-2.5	—	—	P-2.5
MWLN R/L2525M08	●	●			25	25	150	25	25	32	—								
MWLN R/L3225P08					32	25	170	25	32	32	—								
MWLN R/L2525M10	△	△	WNM□□1006□□	1.2	25	25	150	30	25	32	—	MSW-533	MLP58	—	MCPM-21	MCS625-3	—	P-3	P-3
MWLN R/L3225P10					32	25	170	30	32	32	—								
MWLN R/L3232P10	△				32	32	170	30	32	40	—								
MWLN R/L4040R10					40	40	200	30	40	50	—								
MWLN R/L3232P13			WNM□□1306□□		32	32	170	38	32	40	—	MSW-633	MLP68	—	MCPM-12	MCS828-4	—	P-4	P-4
MWLN R/L4040R13					40	40	200	38	40	50	—								

Note : Parts in parenthesis are optional parts. For part assembly see p. 157.

Reference guide

Parts for M-type

P. 157 ~ 159