



Special Round Piercing Punches – with trombone neck head

Similar to **DIN 9861 Part 1 Standard finish**

Type DA

– with continuous shaft

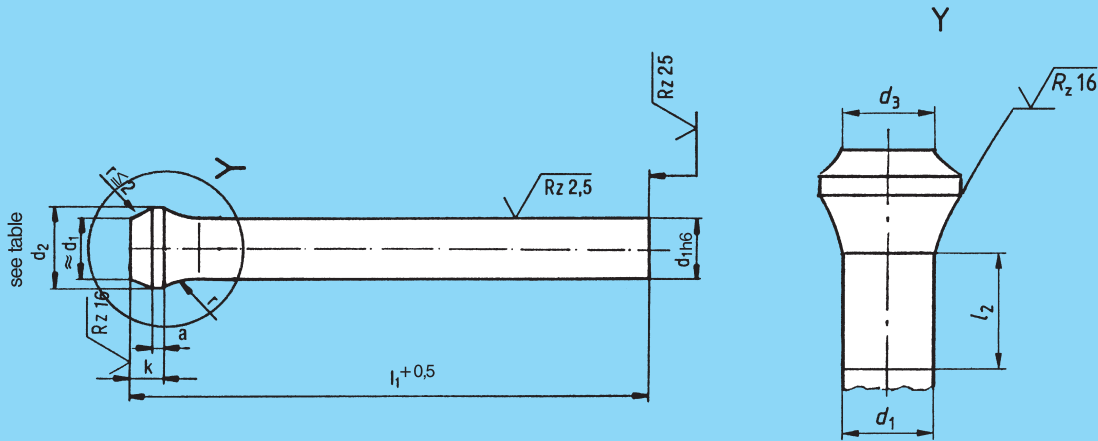

Range of application

For press tools used for extremely high demands

Size/head size

See table - all dimensions are in mm

Fit/tolerances

Nominal diameter d_1 (shaft)

h6	0,50 - 3,00 Ø	≥ 3,00 - 6,00 Ø	≥ 6,00 - 10,00 Ø	≥ 10,00 - 16,00 Ø
	- 0,006	- 0,008	- 0,009	- 0,011

Length: total $I_1 + 0,5$

All other tolerances: see illustration and table respectively for non-specified tolerances in accordance with ISO 2768-m

Material

HWS: High alloy cold working steel (approx. 12 % Chrome)

HSS: High speed steel

Material properties

HWS: For working higher strength materials
High wear resistance - long life

HSS: For working high strength or difficult to work materials. Very abrasion proof high tensile strength and high heat resistance.

Hardness

		HWS	HSS
Shaft:	HRC	60 - 64	62 - 66
Head:	HRC	45 - 55	45 - 55

Finish

Hardened, annealed, shaft precision ground, trombone neck head hot formed with permissible swelling d_3 immediately below the head.

Please note

HSS piercing punches can be treated with a special surface coating on request (pages 42/43).

The necessary counterbores are also available from us.

As required, the head pivot can be omitted. Please indicate when ordering.

Table of dimensions

Piercing punches Type DA with trombone neck head

Shaft-Ø d ₁ h ₆	Total length l ₁ ^{+0,5} 71	Head		Head edge a ±0,1	Head pivot K +0,2	Swelling		Shaft-Ø d ₁ h ₆	Total length l ₁ ^{+0,5} 71	Head		Head edge a ±0,1	Head pivot K +0,2	Swelling			
		Ø d ₂ -0,1 ²	r -0,2			d ₃	Length l ₂ max.			Ø d ₂ -0,1 ²	r -0,2			d ₃	Length l ₂ max.		
2,0		3,0	3,5	1,0	3,0	d ₁ +0,03	5	5,5		8,0	10,0	1,5	4,0	d ₁ +0,03	6		
2,1		3,2	5,0					5,6									
2,2								5,7									
2,3		3,5						5,8									
2,4								5,9									
2,5								6,0									
2,6		4,0	6,5					6,1		9,0	12,0					6,2	
2,7								6,3									
2,8								6,4									
2,9								6,5									
3,0		4,5		7,0		13	15,0	4,0	7,5								
3,1				7,5													
3,2		5,0		8,0	8,0					15,0	4,0	8,5					
3,3					9,0												
3,4					9,5												
3,5					10,0												
3,6			10,5														
3,7			11,0														
3,8			11,5														
3,9			5,5		1,5	4,0	12,0		1,5			4,0	12,5				
4,0		13,0															
4,1		13,5															
4,2		14,0															
4,3		6,0	8,0	1,5			4,0	15,0		4,0	14,5						
4,4											15,0						
4,5											15,5						
4,6											16,0						
4,7											16,0						
4,8											17,0						
4,9		7,0			10,0	1,5			4,0		15,0	4,0	18,0				
5,0													18,0				
5,1													19,0				
5,2													20,0				
5,3																	
5,4																	

The filled-in spaces indicate standard dimensions. Special dimensions on request.
 These piercing punches are also available in type CA (with stepped shaft).

Piercing punches with bottle neck head are not a stock item.